

Building Blocks

Throughout this worksheet, we will go over the neural network building blocks: hidden layer, activation function, loss, and optimizers. *Please refer to slides if you have questions.*

1 NNs

Val is using the following Neural Network to rank his favorite integers. The network takes in an integer, and outputs a favorability score. However, his computer has broken, and he needs to feed-forward by hand. What would the network output given the input “8”?

1.1 ReLU equation

Val is using Rectified Linear (ReLU) activation function. What is the equation for this activation function?
Fill in the circles below with the correct values.

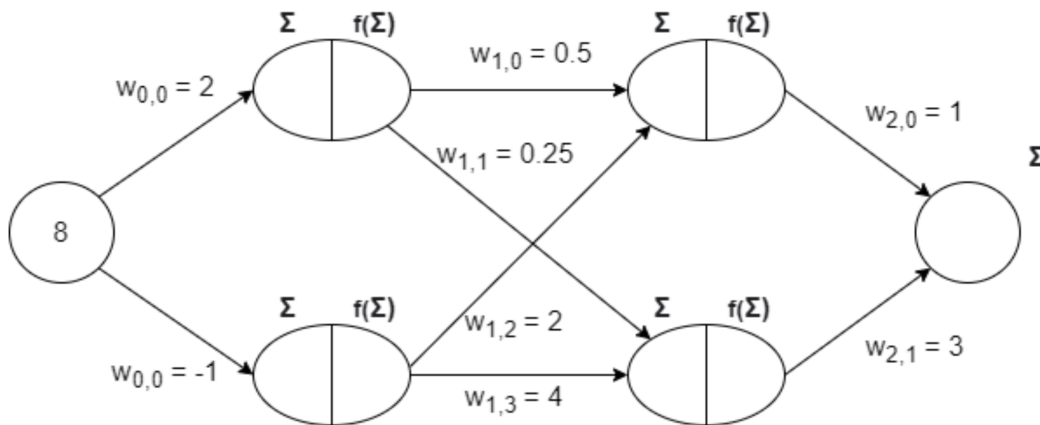

1.2 Feed-forward equation

Let's say we have a neural network with 3 hidden layers. The dimensions of each hidden layer are h_1 , h_2 , and h_3 . The feed forward equation for a given hidden layer looks like this:

$$y = \sigma(Wx + b)$$

where σ represents some activation function.

Consider the second hidden layer.

- What does each matrix/vector represent? If it is a matrix, what does each row/column represent?
- What are the dimensions of each matrix/vector?

2 Activation function

- (a) What does activation function do? What are the requirements for an activation function?

- (b) Name at least 4 activation functions, sketch them, and explain when to use which one.

3 Loss function

- (a) What is a loss function?

- (b) Name some loss functions and explain when to use them.

4 Optimizers

- (a) What is an optimizer?

- (b) What does "stochastic" in Stochastic Gradient Descent mean?

- (c) Name 2-3 examples of optimizers and explain how they work/differences between them.